

## YS Series Y-Strainers

1/2", 3/4" AND 1" PVDF

### KEY FEATURES

- PVDF 1-pc Construction
- NPT or BSP Threaded Ends
- Socket Fusion Ends for IPS Schedule 40 / 80, or for SDR21 / 33 Piping
- Horizontal or Vertical Installation
- FPM O-Ring Seals
- Hex Cap for Easy Access to Screen
- Standard Screen has 3/32" Perforation

### MATERIALS

- Natural PVDF per ASTM D3222 Type 1
- FPM O-Ring Seals



## TECHNICAL INFORMATION

### EXPLODED VIEW

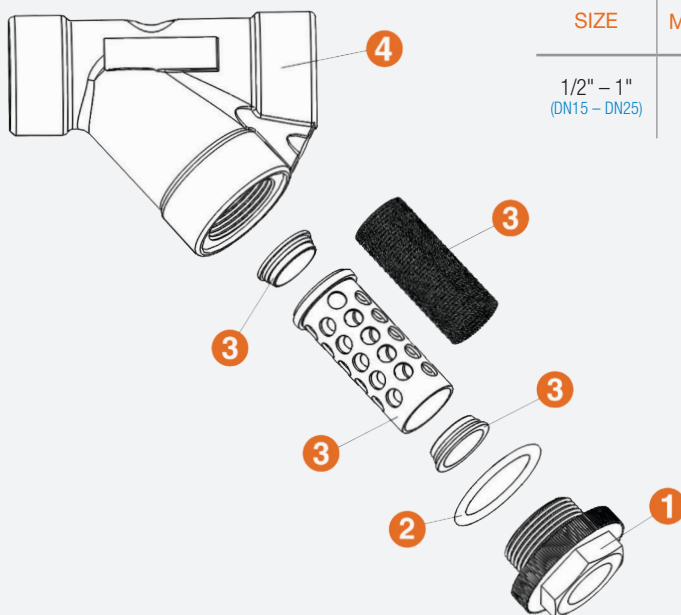

### SELECTION CHART

SIZE	MATERIAL	END CONNECTION	SEALS	PRESSURE RATING
1/2" - 1" (DN15 - DN25)	PVDF	Socket Fusion or Threaded	FPM	150 PSI @ 70°F Non-Shock

# YS Series Y-Strainers

1/2", 3/4" AND 1" PVDF



www.monarchindustrial.com.au  
www.monarchasiapacific.com.au

## TECHNICAL INFORMATION, CONTINUED

### PARTS LIST

1. Cap
2. O-Ring Seal
3. Cartridge
4. Body

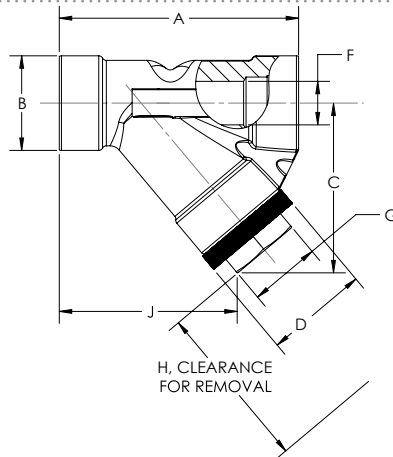

### SCREEN OPTIONS

PERFORATION SIZES	BASKET MATERIAL
1/16"	PTFE / PVDF
3/32"	

### DIMENSIONS

SIZE in / DN	A in / mm	B in / mm	C in / mm	D in / mm	F in / mm	G in / mm	H in / mm	J in / mm	WEIGHT
									lbs / kg
1/2 / 15	3.30/84	1.50/38	2.30/58	1.40/36	0.50/13	1.00/25	2.20/56	2.80/71	0.33/0.15
3/4 / 20	4.1/104	1.90/48	3.00/76	1.90/49	0.75/19	1.25/32	2.70/69	3.20/81	0.82/0.37
1 / 25	5.0/127	2.00/51	3.60/91	2.10/53	1.00/25	1.50/38	3.50/89	3.90/99	1.14/0.52

Dimensions are subject to change without notice – consult factory for installation information

### Cv VALUES\*

SIZE in / DN	Cv VALUES
1/2 / 15	4.0
3/4 / 20	6.8
1 / 25	9.0

\* With standard 3/32" perforation.

### PRESSURE LOSS CALCULATION FORMULA

$$\Delta P = \left[ \frac{Q}{C_v} \right]^2$$

$\Delta P$  = Pressure Drop  
 $Q$  = Flow in GPM  
 $C_v$  = Flow Coefficient

### OPERATING TEMPERATURE/PRESSURE

